

Orites

Field proven
industrial lubricant

The winning solution
for **LDPE** processing



TotalEnergies

Summary

- Reliable proven solution for LDPE and EVA processing
- Technical data and specifications
- Benefits offered by TotalEnergies Lubrifiants
- 5 good reasons for choosing TotalEnergies Lubrifiants

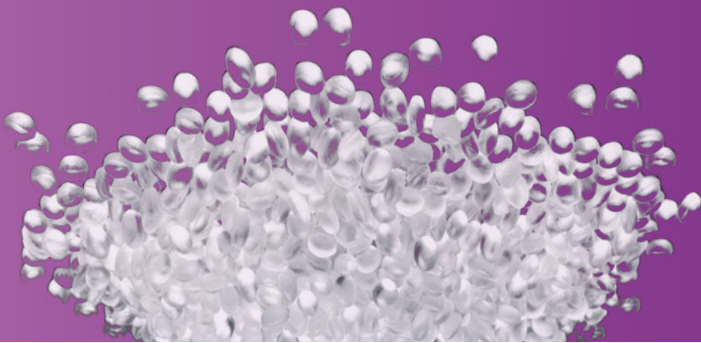

Optimizing the productivity and reliability of petrochemical plants is an on-going challenge. This is especially true for LDPE plants using temperatures exceeding 200 °C and pressure up to 3000 bars. In these harsh conditions, Orites oils are the reliable proven solution for LDPE and EVA processing.

With 50 years of experience in the petrochemical industry TotalEnergies Lubrifiants is your partner of choice for increasing the **safety** and **efficiency** of your plant operation.

Your challenges

- **To protect** process equipment operating under the harshest conditions over long service intervals
- **To reduce** production **downtime** and maintenance cost
- **To lengthen the lifespan** of lubricant and equipment
- **To comply** with the most stringent regulations: US FDA 21 CFR Ch. 1, **Plastic Regulation EU 10/2011**, Pharmacopeia

Our solutions

- **Orites DS series** display a high resistance to ethylene wash-out and enables an efficient lubrication of the mechanical parts (plunger / packings)
- **Orites TW series** provide higher flexibility to specific requirements: pharmaceutical use, HV electrical cable insulators
- **Finavestan** series are high purity oils providing efficient and safe cooling
- All components of **Orites and Finavestan** are identified in FDA regulations 21 CFR 178. 3570

CRANKSHAFT LUBRICATION

Dacnis 150	Cirkan RO 150	Cirkan RO 220
Mineral 150 cSt @ 40 °C		Mineral 220 cSt @ 40 °C
<ul style="list-style-type: none"> • Outstanding anti-wear and anticorrosion properties • Reinforced protection of highly loaded equipment 		
<ul style="list-style-type: none"> • ISO 6743-3: DAG and DAB 	<ul style="list-style-type: none"> • ISO 6743-4 HM • ISO 12925-1 CKC 	<ul style="list-style-type: none"> • ISO 6743-4 HM • ISO 12925-1 CKC

FLUSHING AND COOLING

Finavestan A 360 B	Finavestan A 520 B
Medicinal white oil 70 cSt @ 40 °C	Medicinal white oil 100 cSt @ 40 °C
<ul style="list-style-type: none"> • High purity: Sulfur and Aromatics free • Odorless and flavorless 	
<ul style="list-style-type: none"> • US FDA, 21 CFR 172.878 et 21 CFR 178.3620 • European regulation 2011/10/CE • GB 9685-2016 • European & US Pharmacopeia 	

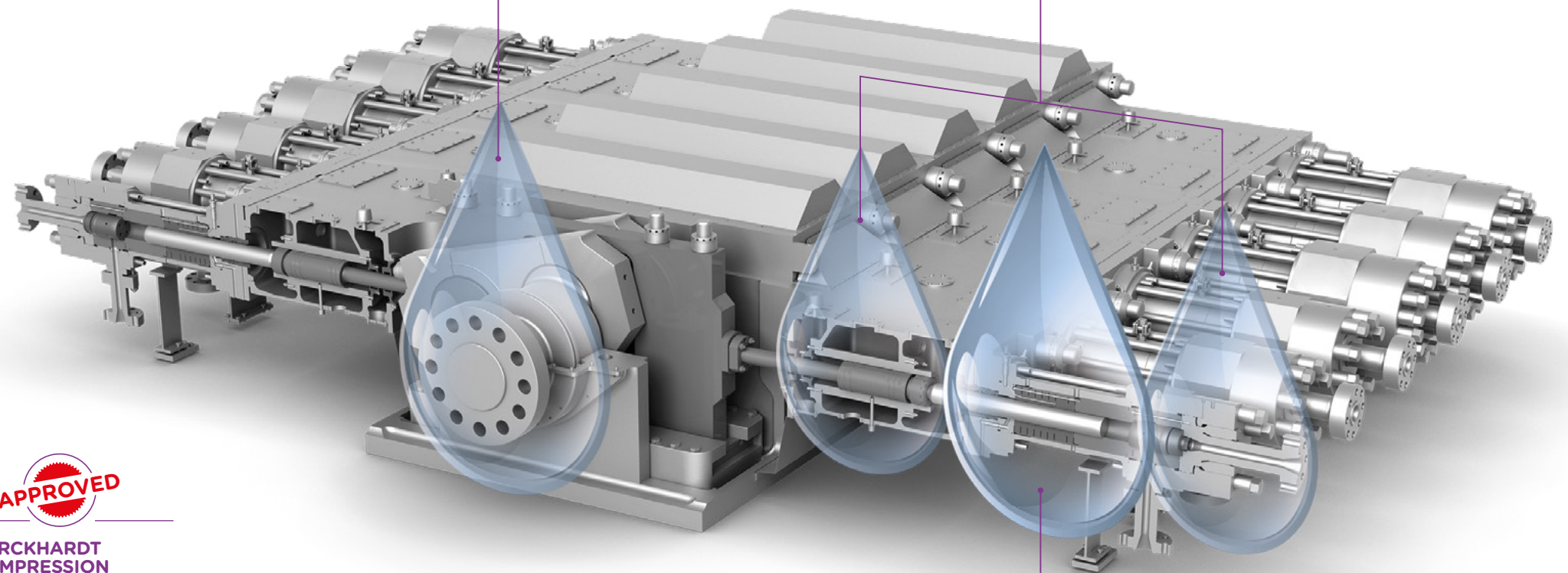

- ✓ BURCKHARDT COMPRESSION
- ✓ BHGE
- ✓ INGERSOLL-RAND

CYLINDER LUBRICATION

Orites DS 270	Orites DS 270 R	Orites DS 270 X	Orites DS 270 D	Orites TW 220	Orites TW 220 X	Orites EDA 220
	Synthetic PAG 270 cSt @ 40 °C				White oil 220 cSt @ 40 °C	
<ul style="list-style-type: none"> • Suitable for LDPE HOMO-polymer • Excellent inherent lubricity leading to packing run cooler and longer 	<ul style="list-style-type: none"> • Suitable for HOMO-polymer • Contains anti oxidant to limit the fouling 	<ul style="list-style-type: none"> • Suitable for LDPE and EVA • Resistance to acid corrosion 	<ul style="list-style-type: none"> • Suitable for LDPE and EVA • Contains anti oxidant to limit the fouling 	<ul style="list-style-type: none"> • Suitable for LDPE HOMO- polymer 	<ul style="list-style-type: none"> • Suitable for LDPE and EVA • Resistance to acid corrosion 	<ul style="list-style-type: none"> • Compatible with EDA co-polymer • LDPE HOMO-polymer

NSF European regulation 2011/10/CE, ISO 6743-3:DGC

NSF European regulation 2011/10/CE, ISO 6743-3:DGC



OUR MOST ADVANCED LUBRICANTS

Orites DS 270

Pressure - Viscosity relationship at 40 °C

- Better HP pumpability
- Longer lifespan of spare parts

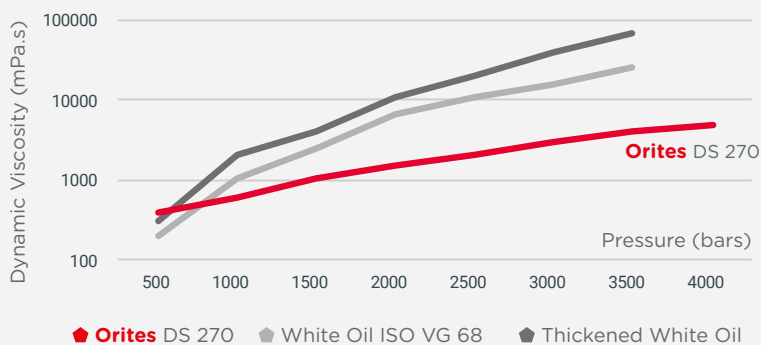

Orites DS 270

Ethylene solubility

- Less oil consumption
- Better conversion rate
- Low cost / performance ratio

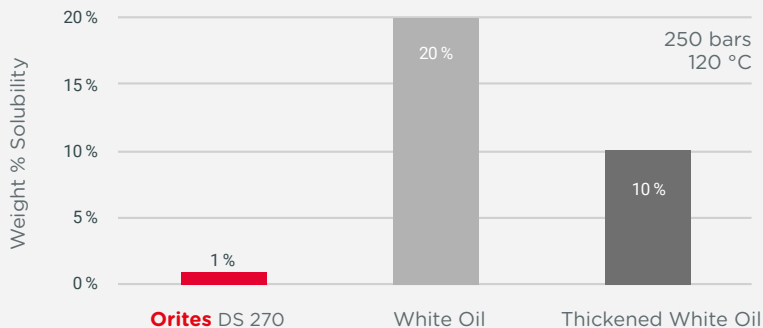

Orites DS 270 X

Corrosion test in presence of Acetic Acid

- Increased packing lifetime by 20 % to 30 %
- Suitable for EVA production up to 40 % VAM

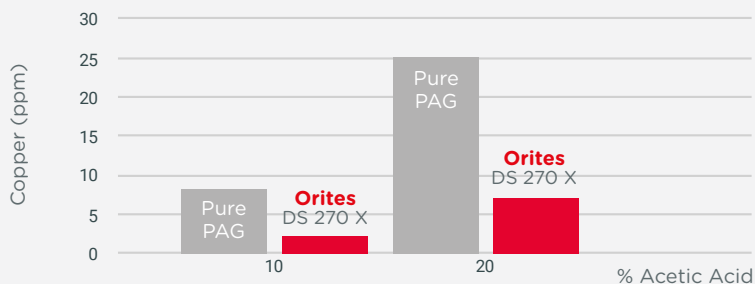





The benefits offered by TotalEnergies Lubrificants

LubAnac

LubAnac provides you a full range of lube oil analysis, to allow you to anticipate and diagnose anomalies in the equipment.

Thanks to LubAnac, you:

-  **Reduce** your operating **costs**.
-  **Anticipate and plan** maintenance operations to perform them at the **best time**.
-  **Optimize** drain intervals and **extend the lifetime** of your equipment.
-  **Improve the reliability and performance** of your equipment.



OUR EXPERT SUPPORTS



Site audit:

- Identification of Critical Point of Lubrication (HACCP approach)
 - Product recommendation, optimization, handling and storage rules
 - Stock rationalization customized on site trainings in order to fit with maintenance team expectations

LubInsight maintenance planner

Optimized maintenance software for your lubricants (CMMS)*

LubInsight Maintenance Planner allows you to boost your productivity through efficient maintenance planning. Built on the expertise of our engineers it offers you to:

-  **Increase efficiency** and savings of your maintenance management.
-  **Monitor lubricant parameters and analyses** with a single tool.
-  **Assert your quality and safety management** through management of lubricant documentation and critical points.

LubInsight Maintenance Planner will help you to deploy and monitor your HACCP** policy on a day to day basis.



THE 7 PRINCIPLES OF HACCP

- Risk analysis
- Critical Control Point (CCP)
- Definition of the critical thresholds
- Establishment of a surveillance system
- Corrective measures
- Verification
- Documentation (HACCP plan)

THE SOLUTIONS OFFERED

- Maintenance plan readings on site
- Data entry in the software
- Identification of the critical points
- Allocation of the NSF H1 lubricants
- Definition of the control analyses
- Management of preventive and condition-based maintenance
- Scorecards for maintenance and critical points
- Document management
- Maintenance history

* Computerized maintenance management software
 ** Hazard Analysis Critical Control Point



A major player

With our production, supply chain and commercial presence in more than 160 countries, we deliver a full range of lubricants.

Support and partnership

Thanks to local technical presence, we provide a high level of service to optimize your Total Cost of Ownership.

References & OEMs

TotalEnergies Lubrificants cooperates with equipment manufacturers to create high-technology products for optimal performance and production of your machinery.



Innovation & Research

TotalEnergies Lubrificants invests in biotechnologies to find the most suitable components to reach energy efficiency through formulations designed in our Research Centers.

Quality and environment

TotalEnergies Lubrificants ISO 9001 and 14001 certifications are the guarantee of a long term commitment to quality and environment. From the initial design stage, our R&D teams seek to develop products that minimize toxicity risks and environmental impact.



TotalEnergies



lubricants.totalenergies.com



✉ ms.industry@totalenergies.com

Safety Data Sheets are available at ms-sds.totalenergies.com



TotalEnergies Industry Solutions